

# Model HS High Capacity Bean Snipper

# Hughes

Equipment Company, LLC

INTERNATIONAL



## Application:

In a typical application, green or wax beans are processed through a Hughes Model H Presnipper and then fed directly to the HS snipper to cleanly snip off both ends of the bean.

## Operation:

Beans enter the reel via the stainless steel infeed chute. The inner reel's 34 octagon 20 gauge stainless steel hemmed baffles then lift the product eight times per revolution increasing the capacity and efficiency by eliminating the "roping" effect with green beans. This lifting separates the beans causing the ends to fall into the slotted pockets along the outside of the drum. Travelling along the outside of the drum are 8 sets of knives that snip off the ends of the beans. These ends are then discharged below while the snipped beans are carried out the discharge chute for further processing.

## Versatility:

The Model HS Snipper offers many benefits and features to give the customer the best value for their money.

1. Higher process capacity per square foot of floor space.
2. Fewer snippers needed frees up processing space as well as requiring less cleaning and maintenance.
3. Localized grease points for easy access and maintenance.
4. Drop down sides for easy access to the reel for maintenance and cleaning.
5. Various pocket sizes for any bean type or sieve size.

## Performance:

The Model HS Snipper features a processing capacity of 6,000 pph while maintaining a 90 - 98% efficiency. With eight rows of knives it ensures this efficiency while giving it a high product surge capacity during peak delivery.

## Standard Unit Construction:

The trunnion mounted sprocket driven drum contains 945 slotted  $1\frac{3}{64}$ " wavy pockets along with 34 20 gauge stainless steel octagon lifting baffles. Holding the baffles and pockets together are mild steel end plates with zinc plated mild steel rods. Traveling along the drum are 92 stainless steel "V" shaped knives in four rows of 12 and four rows of 11 held in place with our patented stainless steel brackets. The stainless steel tubular frame has adjustable legs at the infeed end as well as stainless steel drop down sides for easy maintenance and cleaning.

## Options:

- Friction Driven Brush Assembly
  - 14 gauge Galvanized or Stainless Steel Baffles
  - Stainless Steel Cylinder Rods
  - Stainless Steel End Plates
  - Stainless Steel Waste Chute
  - Inner Drum Deflector (For a Cushioned Fall inside the reel)
  - Spray Manifold
- Various Pocket Sizes:
    1.  $1\frac{10}{64}$ " (4 mm)    Straight or Wavy
    2.  $1\frac{13}{64}$ " (5mm)    Straight or Wavy
    3.  $1\frac{15}{64}$ " (6 mm)    Straight
    4. Customer specific sizes upon request

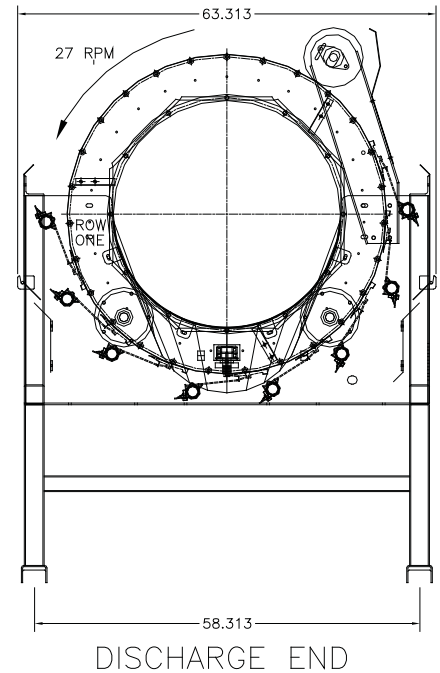
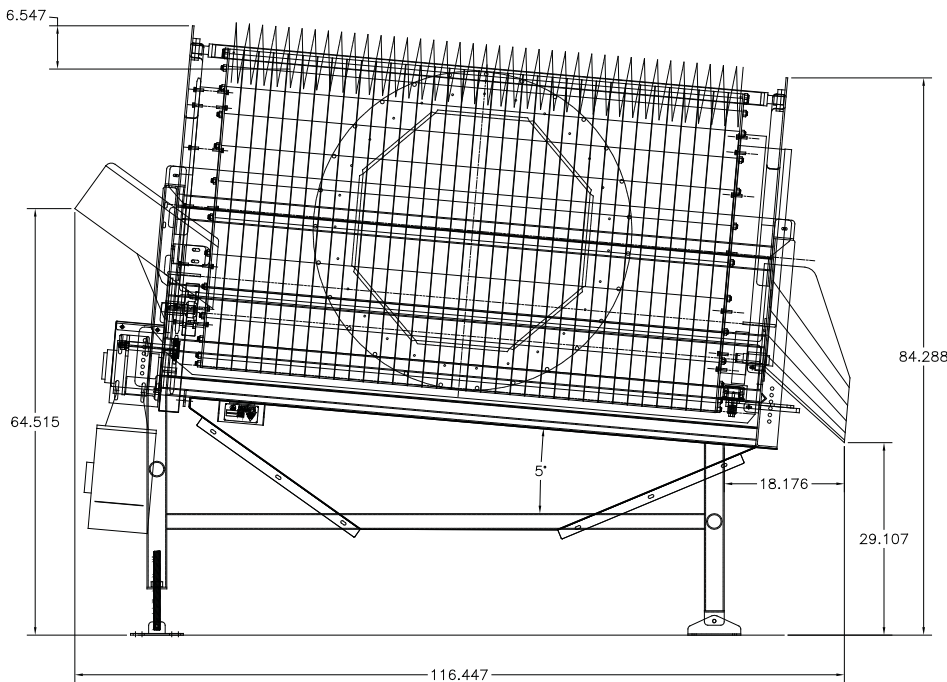

**Hughes**  
Equipment Company, LLC  
INTERNATIONAL

1200 West James Street, Columbus, WI 53925  
Phone: (920) 623-2000 ~ (866) 535-9303 ~ Fax: (920) 623-4098  
E-Mail: [hughes@hughesequipment.com](mailto:hughes@hughesequipment.com)    [www.hughesequipment.com](http://www.hughesequipment.com)